



# SWINGING DOOR INSTALLATION GUIDE

Wood Framing - New Construction

# IMPORTANT NOTICES & INFORMATION

The building envelope must be correctly prepared with weather resistant barriers – that meet local and state codes. All frame and sill surfaces must be correctly prepared for air, water, and structural integrity by the builder or contractor before attempting installation. In order to meet warranty requirements, all systems are required to be installed by a certified installer.

- Read these instructions in their entirety prior to installing windows. Contact Loewen at 1.800.563.9367 for clarification.
- Loewen is not responsible for site measurements nor the structural and architectural requirements for the installation of the windows.
- Building design, construction methods, building materials and site conditions unique to your project may require methods different from these instructions.
- Choosing the appropriate method is the responsibility of you, your architect, or your construction professional.
- Confirm with sealant/foam/barrier manufacturers that all materials used are compatible with one another.
- Remove shipping blocks and related staples prior to installation.
- All drawings are shown not to scale.
- To ensure accuracy, make sure you have the latest approved shop drawings and assembly and installation guides.
- Any local, regional or national building code requirements supersede these instructions.
- Safety is top priority for Loewen. Use proper work procedures and protective equipment.

## Notes on Building Envelopes

Improper design and/or non-conforming application of building envelope materials has been demonstrated to cause premature building envelope failure. Even with premium materials, shortcuts and errors in the final installation can impact budgets, time frames, building life span, and increase legal liabilities.

As one of the elements that bisect the interior/exterior plane, window and door integrations are a critical element of the building envelope as a whole. Poor installations can carry significant liability, due to building envelope failure.

## Finishing Requirements

### Metal Clad:

- Interior - within 14 days of installation.
- All door panels - Interior - immediately upon installation.

### Non-clad:

- Exterior - immediately upon installation.
- Interior - within 14 days of installation.
- All door panels - Interior and Exterior - immediately upon installation.

### Factory primed:

- Exterior - within 14 days of installation.
- Interior - within 14 days of installation.
- All door panels - Interior and Exterior - immediately upon installation.

See Loewen warranty and finishing guidelines at [www.loewen.com](http://www.loewen.com)

## Site Preparation Advisory

This instruction assumes that exterior of building envelope is correctly prepared with weather resistant barriers – that meet local and state codes.

It is recommended that Loewen Door systems are installed with sufficient overhangs to aid in prevention of water or air infiltration that may contribute to structural damage to the surrounding area, finishes and/or systems.

## Tools Required

- Laser Level
- Hammer
- Pry Bars
- Ladders
- Utility Knife
- Cordless Drill
- Foam Gun Applicator
- “J” Roller
- Tape Measure
- Caulk Gun

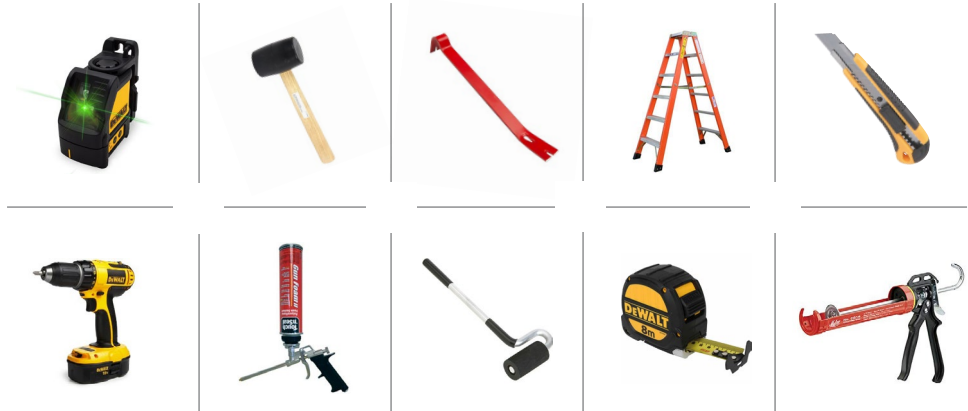

## Materials Required

- High Impact Composite (not wood) shims/spacers
- 1 1/2” or 2” #8 Screws (stainless steel recommended)
- Expansion Foam - Closed Cell (low-expansion only)
- Window & Door Flashing Tape (6” recommended)
- Window & Door Sealant
- Interior Trim



## Weather Barrier Material Selection

Though this guide only includes one type of barrier material, various options are available to meet individual site requirements:

- Vapor Permeable Building Wraps
- Fluid Applied Materials
- Self-Adhered Membranes
- Medium Density Spray-Polyurethane Foam
- Rigid Board Stock Insulation
- Factory-Bonded Membranes to Sheathing

## Product Adjustments

Adjustments to Loewen products are required as part of the installation process. It is up to the installer to ensure that all products operate properly and seal adequately.

Adjustments to hinges and other hardware to achieve uniform reveals and consistent weatherstrip contact should be made and verified during the installation.

Should technical support be required please contact us at 1-800-563-9367.



## 1. Verify & Prepare the Rough Opening

- a. Measure the rough opening (RO) and the door frame assembly to determine that the size is correct. Loewen recommends the rough opening is between 3/4" - 1" larger than the door width and height. Ensure that the rough opening is plumb, level and square, and that the walls in the opening are not twisted. Ensure that the RO will be able to accommodate the added height of a sloped sill pan (as recommended).
  - ii. 1 1/2" solid blocking is required at the sill and sides of the opening.
  - iii. Ensure proper header is in place before installation.

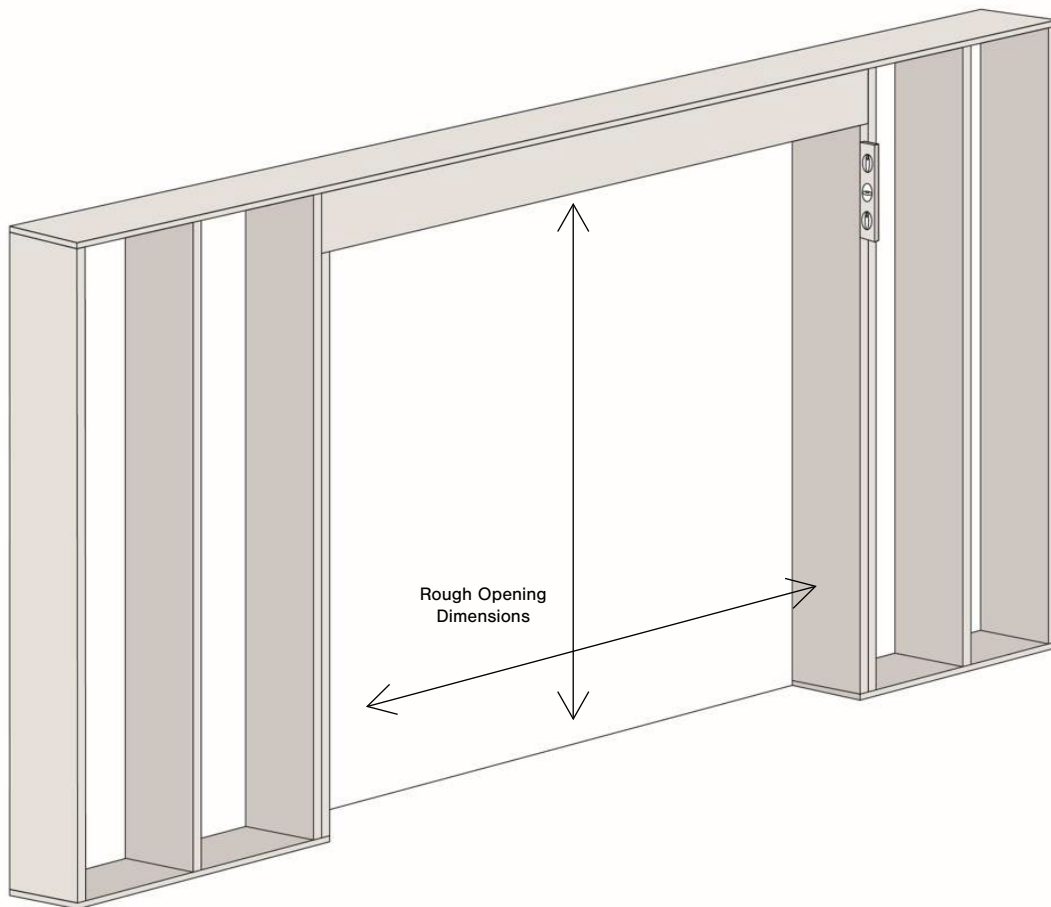

## 2. If Weather Resistant Barrier (WRB) house wrap is applied, then execute a box cut

- a. Cut back and expose the sheathing at the side jambs by removing approximately 1 1/2" of WRB. This will allow a direct-contact seal to the sheathing.
- b. Create a temporary flap at the head of the opening by cutting the WRB at a 45-degree angle. Temporarily tape the flap up out of the way to allow for door installation and head flashings.
- c. NO WRB should be brought into the rough opening.
- d. Sill Pans and flashing must be applied to rough openings and are designed to divert and drain water directly to the exterior or onto the weather resistive barrier. Sill pans are mandatory in any door installation.



## 3. Preparing Sill Pans & Sealant Application

- a. For illustration purposes, here are three different sill pan options:
  1. Rigid sill pan.
  2. Soft flashing tape sill pan.
  3. Wet application pan flashing.

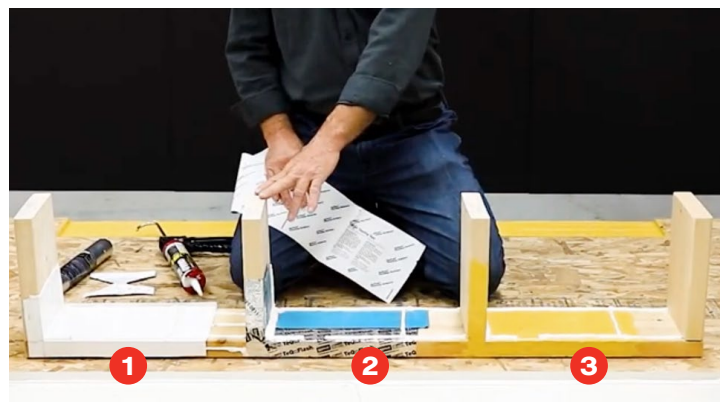

### 3. Preparing Sill Pans & Sealant Application (Continued)

- b. All Sill Pans should be sloped to the outside with a minimum 1/2" interior upturn leg or dam and 2" exterior down-turn leg. The up-turned leg at the frame jamb should be 6" tall.



- c. In all applications apply a sealant bead on top of the sill pan flashing along the exterior of the rough opening, leaving a 2" void approximately 2" from either end. This will allow a drainage path for incidental moisture.

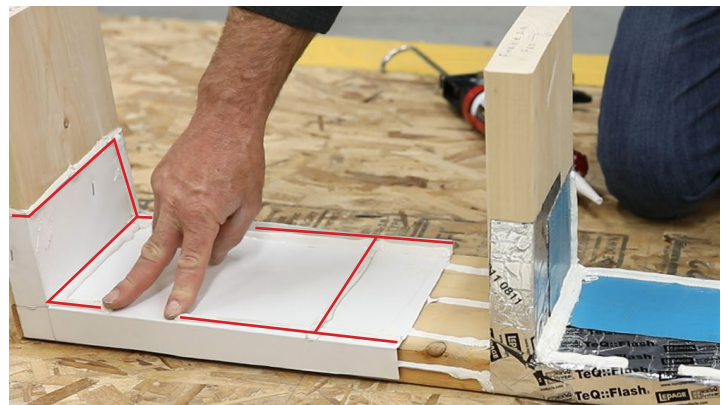

- d. Along the jamb side of sill pan where the jamb leg will sit up against apply a continuous bead on the interior edge up the sill leg. Red lines illustrate the completed sealant application.

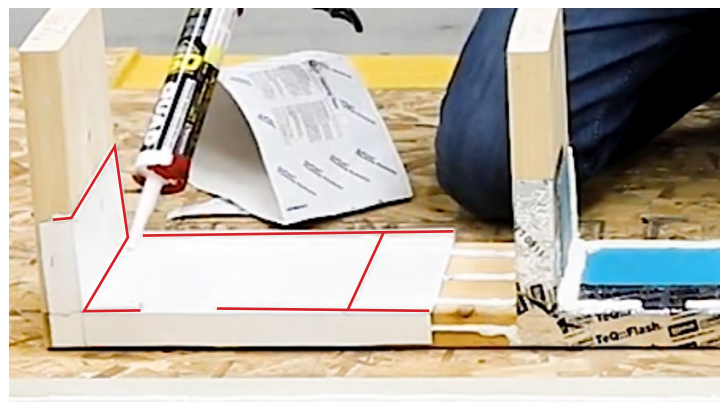

- e. Once the sill preparation is complete, Place shims at each end at location of jamb legs to ensure the door frame will be appropriately levelled and door will sit just proud of the sill pan.



- f. On the exterior sheathing apply a sealant bead from the sill pan leg to the wall sheathing and apply a continuous bead all the way around on three sides of the rough opening. Sealant is applied on the sheathing substrate edge.



- g. Caulking beads should line up with nailing flange holes so that screws will be driven through this sealant.

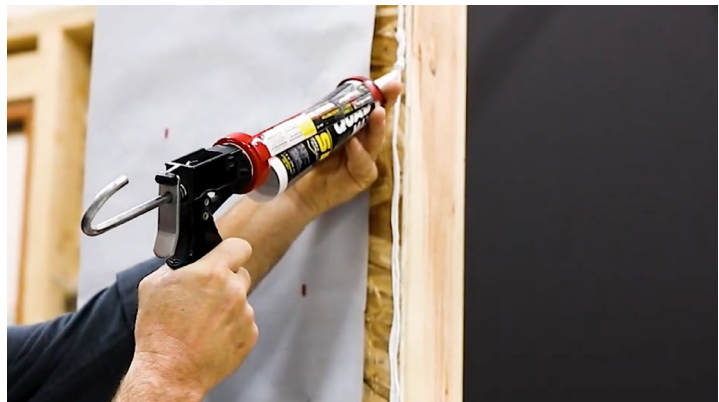



#### 4. Installing Door Frame into Rough Opening

- a. Set the door from the exterior into the rough opening, starting with the bottom edge, on the sill pan. The jamb legs should be sitting on the sill shims on each side.
- b. Tilt the door up and push the top of frame into place
- c. Apply a screw through each top corner of the flange to temporarily secure the door.



- d. Using a level and/or laser, ensure the unit is level, and that the side jambs are completely square and plumb.
- e. If necessary, remove the screws and adjust the door frame in place.
- f. Confirm that the gaps between the door frame and the door panels are even.





- g. For typical installations, apply screws through every second flange hole. In coastal applications, it is required to apply 2" stainless steel screws through every hole.
- h. Ensure that screws go in straight and perpendicular and not angled, to avoid creating a bow in the jamb, creating wide cavities in between frame and rough opening.
- i. From the interior, apply shims behind every hinge, leaving a 1/2" gap from the flange to ensure there is space for insulation foam to create a continuous seal. Composite shims are preferred.



---

**Warning: insufficient shim support behind the shims will result in frame spread and panel gapping**

---

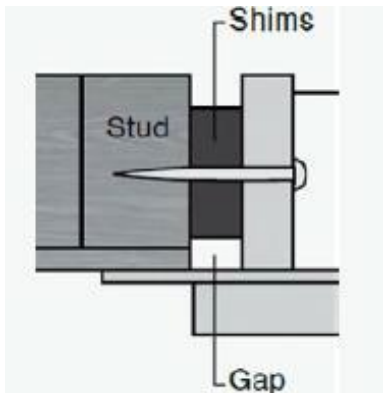

## 5. Anchoring the Hinges

- a. A fastener package is provided, attached to the door panels, containing adjustment shims (for concealed bearing type hinges), a construction handle and hinge anchor screws.



- b. Each hinge has miss-matched jamb screws, located adjacent to the frame weatherstrip

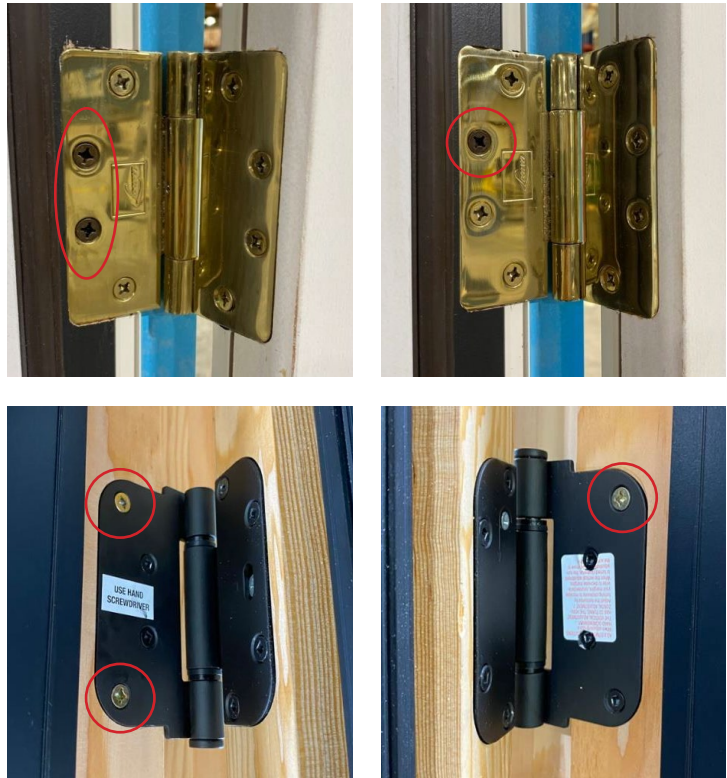

- c. Remove the non-matched colored screw and drill a pilot hole through the door frame.



- d. **Important for outswing doors:**  
Inject sealant into the empty screw holes before applying the anchor screws.



- e. Install the supplied long anchor screws in each open screw hole





- f. The screws will be driven through the frame, framing shims, and secure the hinge assembly to the frame studs

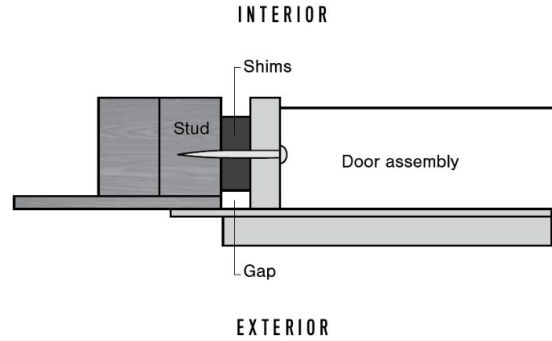

- g. Ensure screws are not overtightened to avoid a gap at latch side or in the centre of the 2 panel doors. If the screws are under-tightened, the door panels may strike each other at the center, or strike the door frame.



## 6. Concealed Bearing Hinge Panel Adjustments

- a. Concealed bearing hinges are shipped with polymer adjustment leaves that may be removed or added to achieve even panel gaps.



## 7. Adjustable Hinge Type Panel Adjustments

- a. Adjustable hinges will have an extra screw on the door side of the hinge that can be adjusted with a hand screwdriver.
- b. The center hinge(s) will have a screw marked "V" for vertical adjustment, which may be turned up to 70 times to lift the panel up or down.

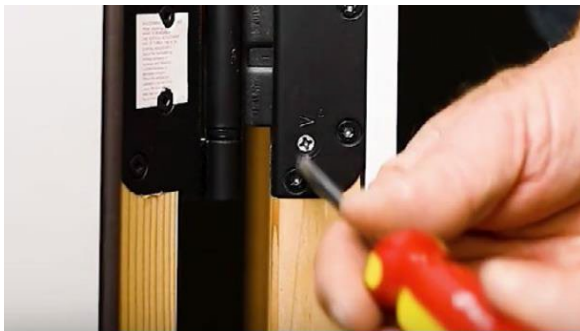

- c. The top and bottom hinges will have a screw marked "H" for horizontal which will move the panel left or right.
- d. Employing a second person to hold the door panel at the opposite edge can make this process easier.

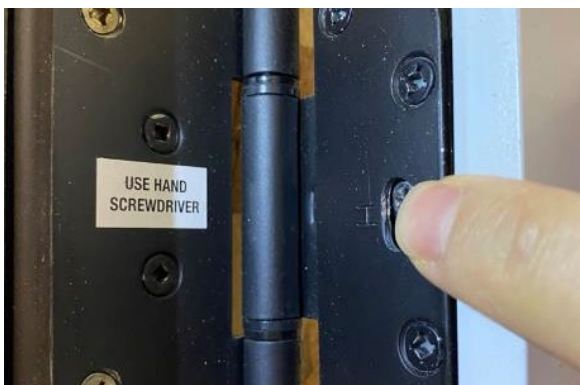

## 8. Sill & Header Strike Plates for 2 Panel French Terrace Doors (1<sup>3/4</sup>" panel\*)

\*Specific strike anchoring will vary by product type

- a. Remove the short screws located in the bottom hardware strike plate on the centre sill



- b. Drill longer pilot holes into the sill pan, then fill holes completely with clear silicone sealant.



- c. Place the plate, then insert long screws from the hardware package into the holes.



- d. Repeat above process for the top strike plate, predrilling and injecting with silicone before applying screws.



**NOTE: Additional anchoring is required for all 2 1/4" Inswing Terrace & French Door frames. Please refer to and follow the supplemental anchoring instructions at the end of this guide when installing any IS 60T doors. Failure to anchor 60T doors in accordance with the instructions will affect the product performance rating.**



## 9. Sealing & Insulating Door Frame

- a. To ensure the sill pan is sealed to the sill itself, apply a sealant bead between the sill pan and the door sill all along the bottom edge



- b. Use an application tool to push the sealant in to ensure the gap is fully sealed.



- c. The rough opening gap may now be sealed with a closed cell, low expansion spray foam.

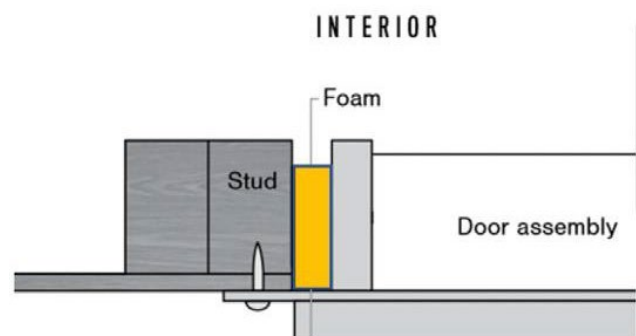

## 9. Sealing & Insulating Door Frame Continued

- d. After the door has been fastened, self adhesive window/door flashing should be applied to the side jambs first.



- e. Apply the top strip of flashing after the sides, extending past the side strips by a minimum of 1" each side.



---

**NOTE: absence of proper flashing may void product warranty coverage.**

---

- f. Use a J roller or firm hand pressure to push out all air pockets and ensure good adhesion.
- g. Apply rigid head flashing if none was applied by Loewen.



- h. Remove the previously applied tape holding the flap of the WRB at the head
- i. Apply slices of window/door flashing over the diagonal cuts made in the WRB. Ensure the entire cut is sealed.



**Basic swinging door installation steps are now completed. Please refer to the supplementary anchor instructions below for 60T, 2 1/4" panel product.**





# 2 1/4" TERRACE & FRENCH DOOR FRAME ANCHOR SCREW INSTALLATION INSTRUCTIONS

## Supplemental Installation Instructions

This supplement demonstrates how to install the required structural Anchor Screws at the Head, Sill and Lock Jamb for the I/S 60T (2 1/4") doors, including FD2/TD1/TD2/TD3 & TD4.

**Important: Always practice safety! Wear the appropriate eye, ear and hand protection, especially when working with power tools.**

## Tools Required

- QUAD / Robertson or Phillips Screwdriver
- High grade silicone



## Catalogue

**Section I:** FD2 Head & Sill Anchor Instruction

**Section II:** TD1 Head & Sill Anchor Instruction

**Section III:** TD2/TD3/TD4 Head & Sill Anchor Instruction

**Section IV:** TD Lock Jamb Strike Plate Anchor Installation Instructions

# SECTION I: FD2 HEAD & SILL ANCHOR INSTRUCTIONS

## Parts in Package



#8 x 2" Pan Head Screws



#10 x 4" Flat Head SS Screws



#12 x 1/2" Flat Head SS Screws

## Installation Steps:

### Step 1:

Install the door from the exterior into the rough opening following the Loewen Swinging Door Installation Guide for Wood Framing - New Construction.

### Step 2:

- Remove the two 3/4" Flat head screws from the head strike plate (Fig a.)
- Replace them with screw #12 x 2 1/2" Flat head SS screws provided.
- Install an additional two #12 x 2 1/2" flat head screws into the two center holes. (Fig b.)

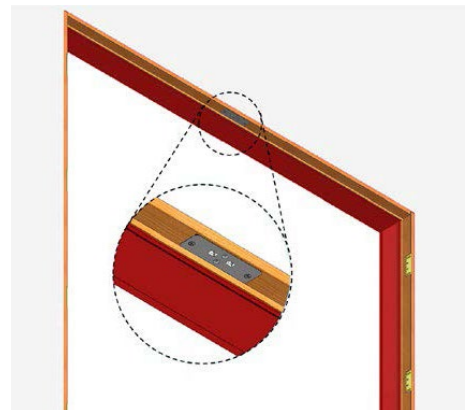

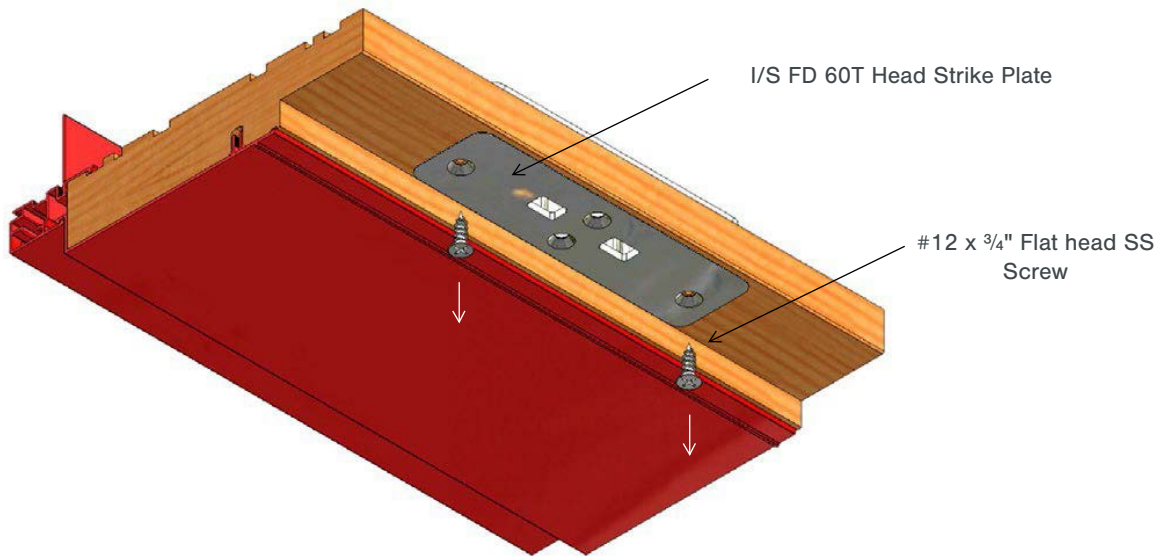

Figure A

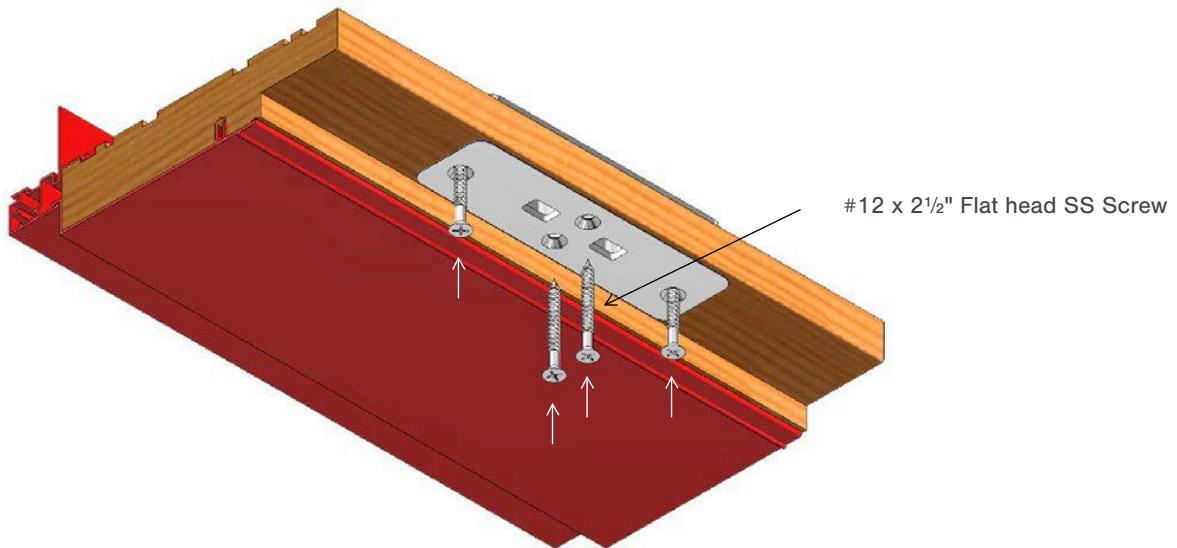
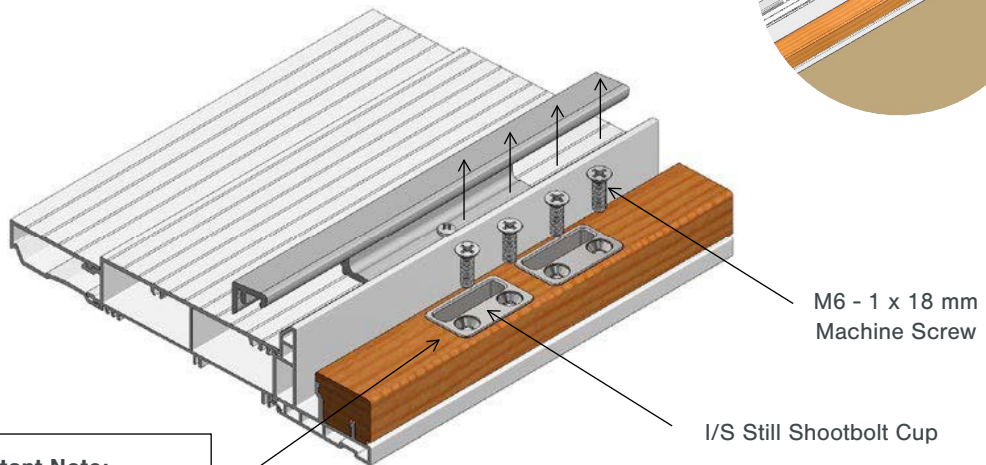
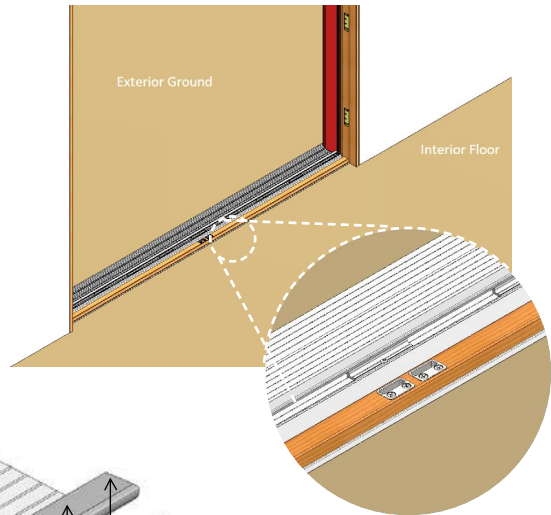

Figure B



**Step 3:**

- Remove the four 18 mm Machine screws from the I/S Sill Shootbolt Cups (Fig c.)
- Predrill 3" deep through the shoot bolt cup screw holes with a 1/8" drill bit.
- Inject a minimum 3 pumps of silicone sealant into each hole.
- Replace Machine screws with the four #10 x 4" flat head SS screws provided. (Fig d.)



**Important Note:**  
Inject all sill strike screw holes with silicone sealant, minimum 3 pumps each.



Figure C

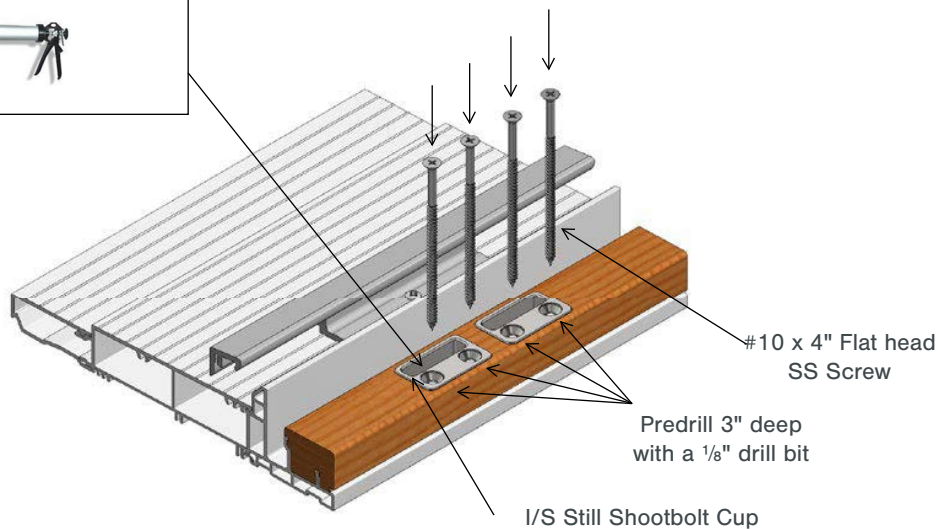
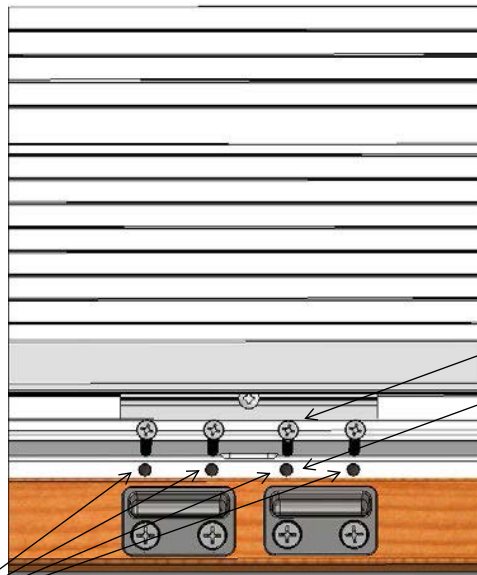

Figure D

**Step 4:**

- Predrill Jamb 1 1/2" deep thru the Strike Plate holes with a 1/8" drill bit.
- Inject a minimum 3 pumps of silicone sealant into each hole.
- Install four #8 x 2" Pan head SS screws in the channel directly in front of the Shootbolt cups and seal the tops of the screw heads with silicone sealant.



Predrill 1 1/2" deep with a 1/8" drill bit

**Important Note:**  
Inject all sill strike screw holes with silicone sealant, minimum 3 pumps each.

#8 x 2 Pan head SS Screw

Screw holes are factory sealed with silicone, apply screws directly through the silicone

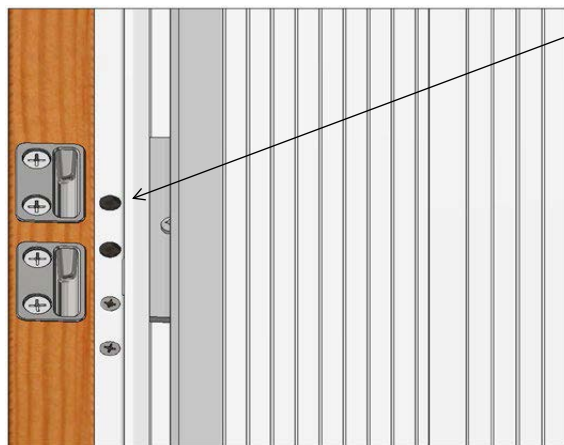

Seal the screw heads using silicone after installation

# SECTION II: TD1 FRAME ANCHOR INSTALLATION INSTRUCTIONS

## Parts in Package



#12 x 2 1/2" Flat Head SS Screws



#10 x 4" Flat Head SS Screws

## Installation Steps:

### Step 1:

Install the door from the exterior into the rough opening following the Loewen Swinging Door Installation Guide for Wood Framing - New Construction.

### Step 2:

- Remove the two 3/4" screws from the Head Strike Plate.
- Predrill Head 2" deep thru the Head Strike Plate holes with a 1/8" drill bit.
- Install provided #12 x 2 1/2" Flat head screws.

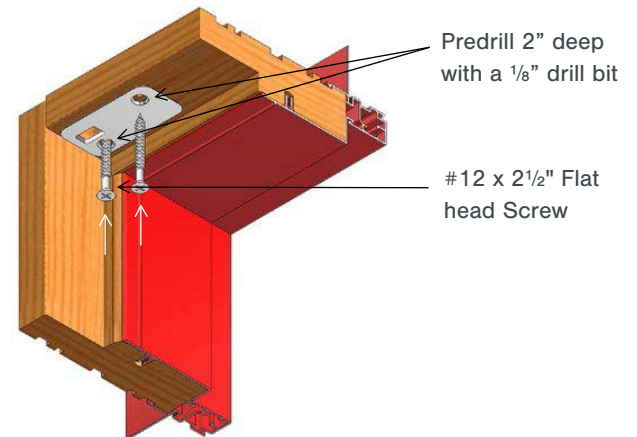
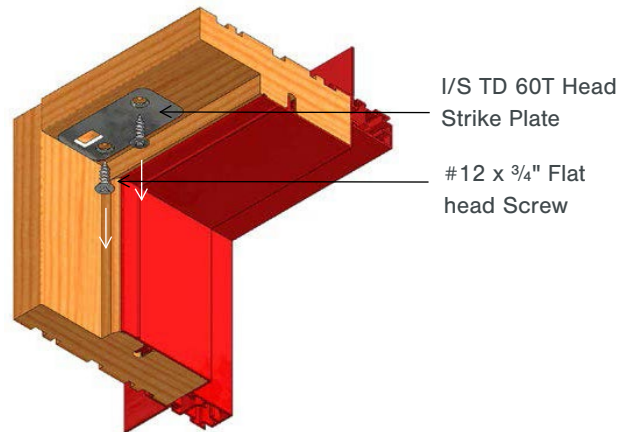

**Step 3:**

- Remove the two Machine screws from the I/S Sill Shoot bolt Cup.
- Predrill Sill cover 3" deep thru the Shoot bolt Cup holes with a 1/8" drill bit.
- Inject a minimum 3 pumps of silicone sealant into each hole.
- Replace Machine screws with two #10 x 4" SS Flat head screws provided.

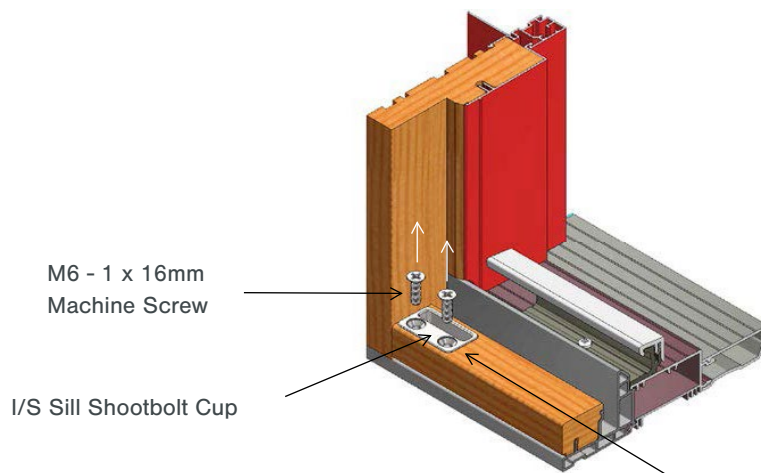

**Important Note:**  
Inject all sill strike screw holes with silicone sealant, minimum 3 pumps each.



This text box contains an important note about applying silicone sealant. Below the text is a small image of a white silicone sealant applicator with a black nozzle and a silver handle.

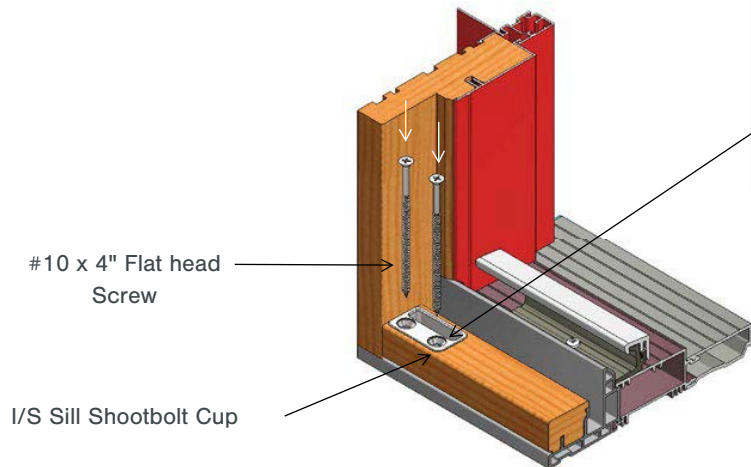



# SECTION III: TD2/TD3/TD4 FRAME ANCHOR INSTALLATION INSTRUCTIONS

## Parts in Package



#12 x 2 1/2" Flat Head SS Screws



#10 x 4" Flat Head SS Screws

## Installation Steps:

### Step 1:

- Install the door from the exterior into the rough opening following the Loewen Swinging Door Installation Guide for Wood Framing - New Construction.

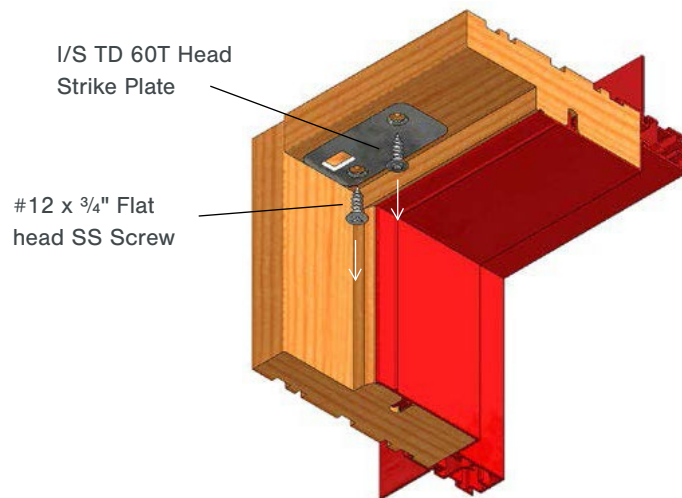

**Step 2:**

Replace them with screw #12 x 2 1/2" Flat head screws provided.

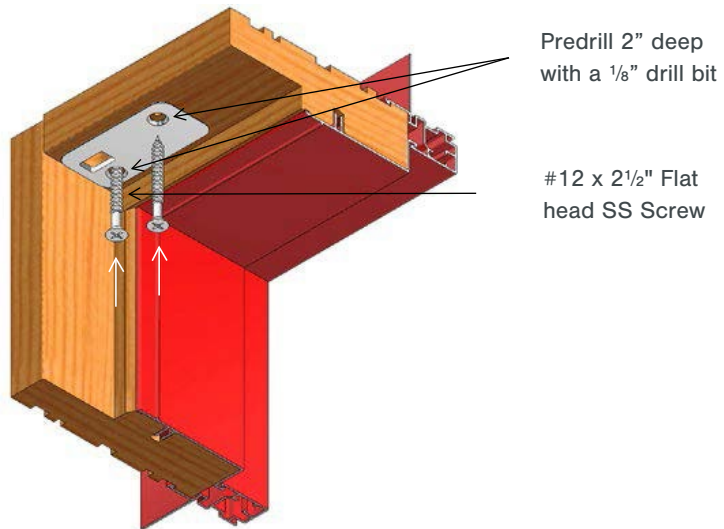
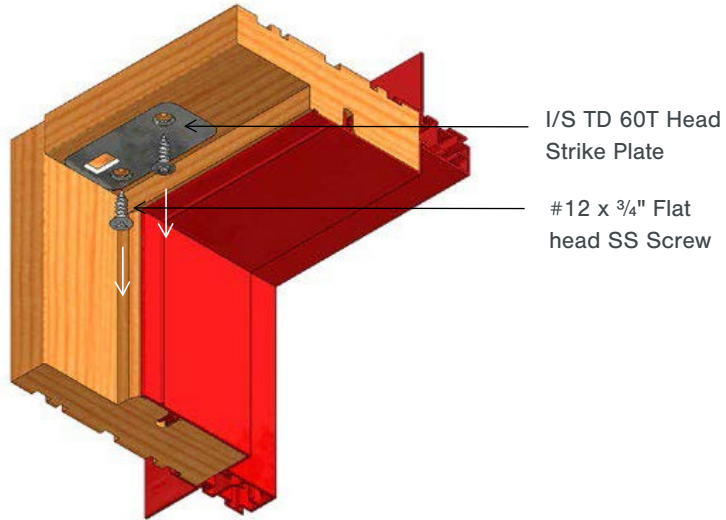

**Step 3:**

- Remove the two Machine screws from the I/S Sill Shootbolt Cup.
- Predrill the holes 3" deep with a 1/8" drill bit.
- Inject a minimum 3 pumps of silicone sealant into each hole.
- Replace them with two #10 x 4" flat head screws provided.

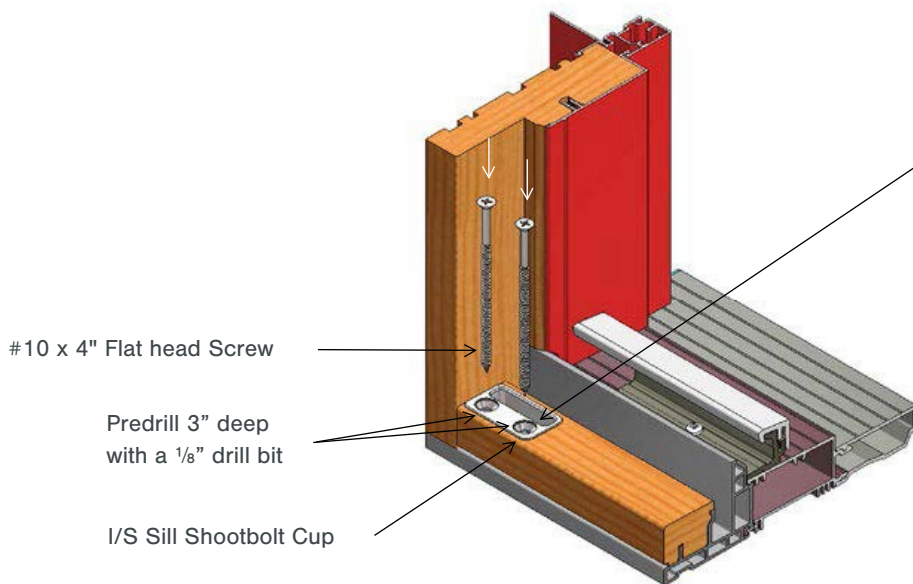
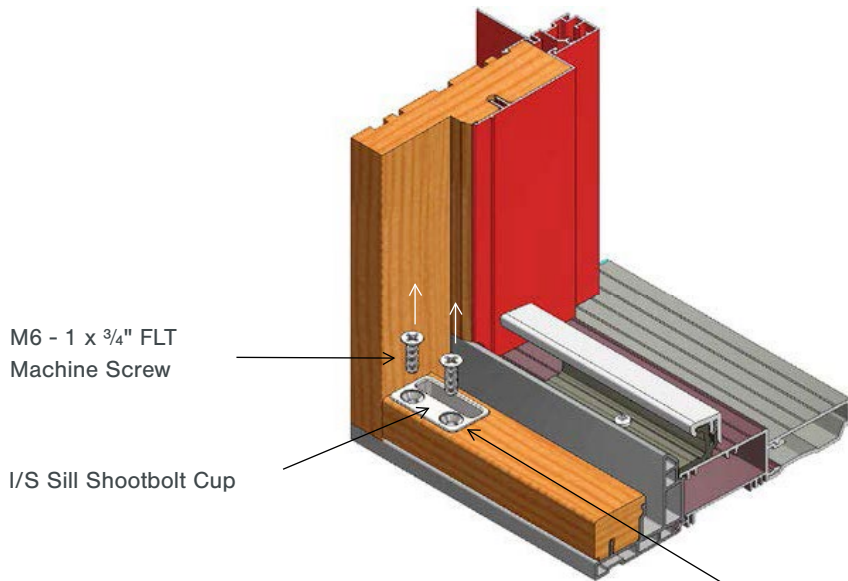

**Important Note:**  
Inject all sill strike screw holes with silicone sealant, minimum 3 pumps each.



A small image of a grey silicone sealant applicator with a black nozzle and a silver trigger.

**Step 4:**

- Remove the  $\frac{3}{4}$ " screw from the Head Strike Plate at the Hinge Stile
- Predrill Head 2" deep thru the Head Strike Plate hole with a  $\frac{1}{8}$ " drill bit
- Replace it with screw #12 x 2  $\frac{1}{2}$ " Flat head screw provided.

**Note:** This is the standard process used on all Fixed Panel Hinge Stiles

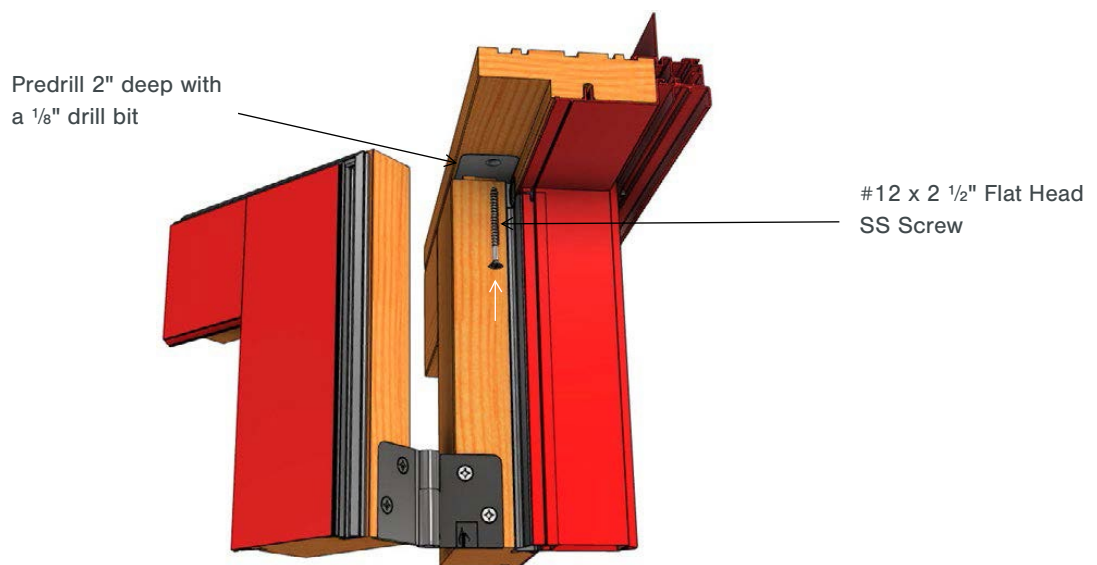
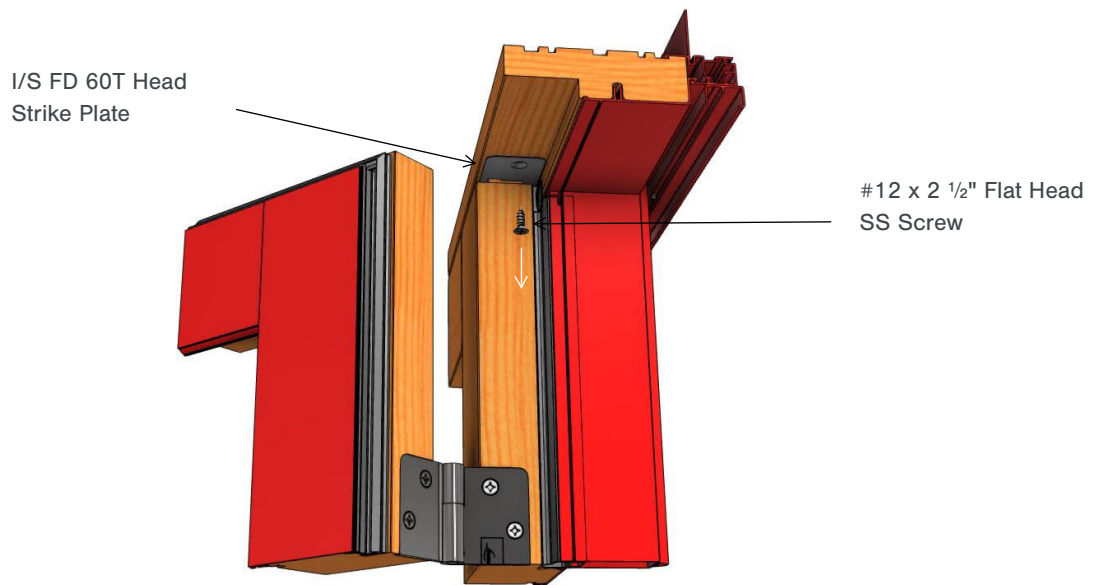



# SECTION IV: TD LOCK JAMB STRIKE PLATE ANCHOR INSTALLATION INSTRUCTIONS

## Parts in Package



8 x 2" Flat Head screws; two per Hook Strike, plus three for the Latch and Deadbolt Strike. Screws will be provided to match Strike Plate finish.

### Important Note:

This section is for units where the Active panel locks at the Jamb directly adjacent to a wall. Skip this section if your door locks into a fixed panel (Optional on multi-panel TD units), or if your unit has another door muller to the Lock Jamb; Anchor screws will be factory applied in these scenarios.

## Installation Steps:

### Step 1:

- After the door has been fully installed, remove the 3/4" Flat head screws from all Hook Strike Plates
- Predrill Jamb 1 1/2" deep thru the Strike Plate holes with a 1/8" drill bit.
- Install #8 x 2" Flat head SS screws making sure to shim behind each Strike Plate.

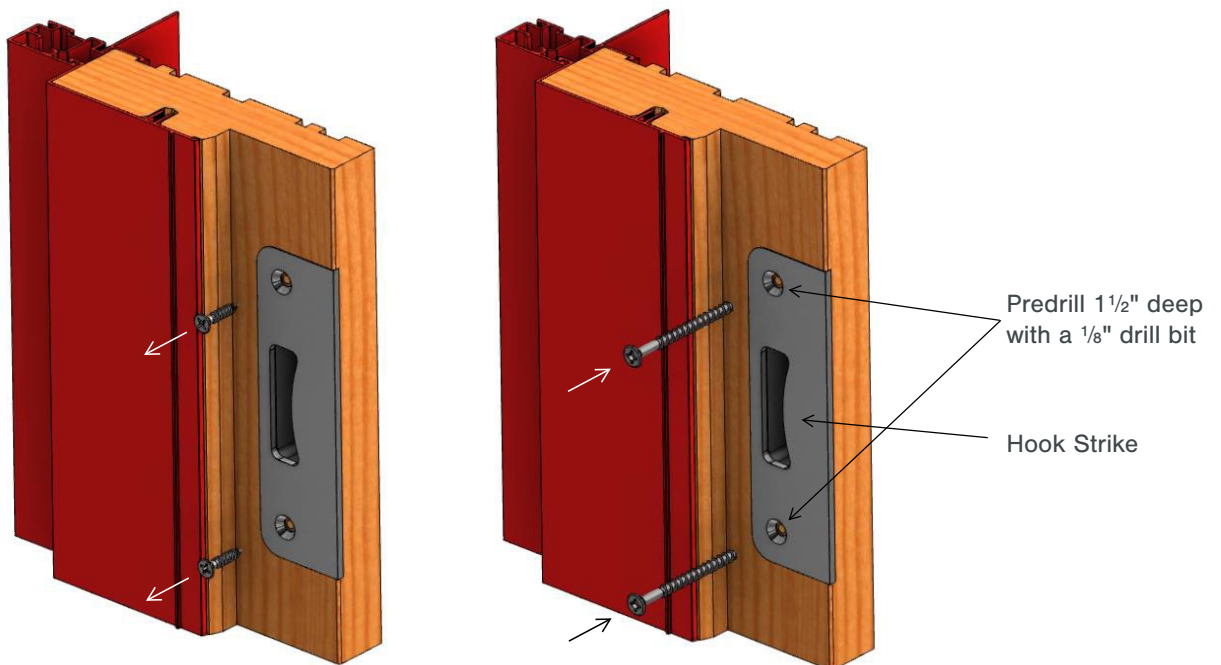

**Step 4:**

- Remove the 3/4" Flat head screws from the Latch and Deadbolt Strike Plate
- Predrill Jamb 1 1/2" deep thru the Strike Plate holes with a 1/8" drill bit
- Install #8 x 2" Flat head SS screws making sure to shim behind the Strike Plate.

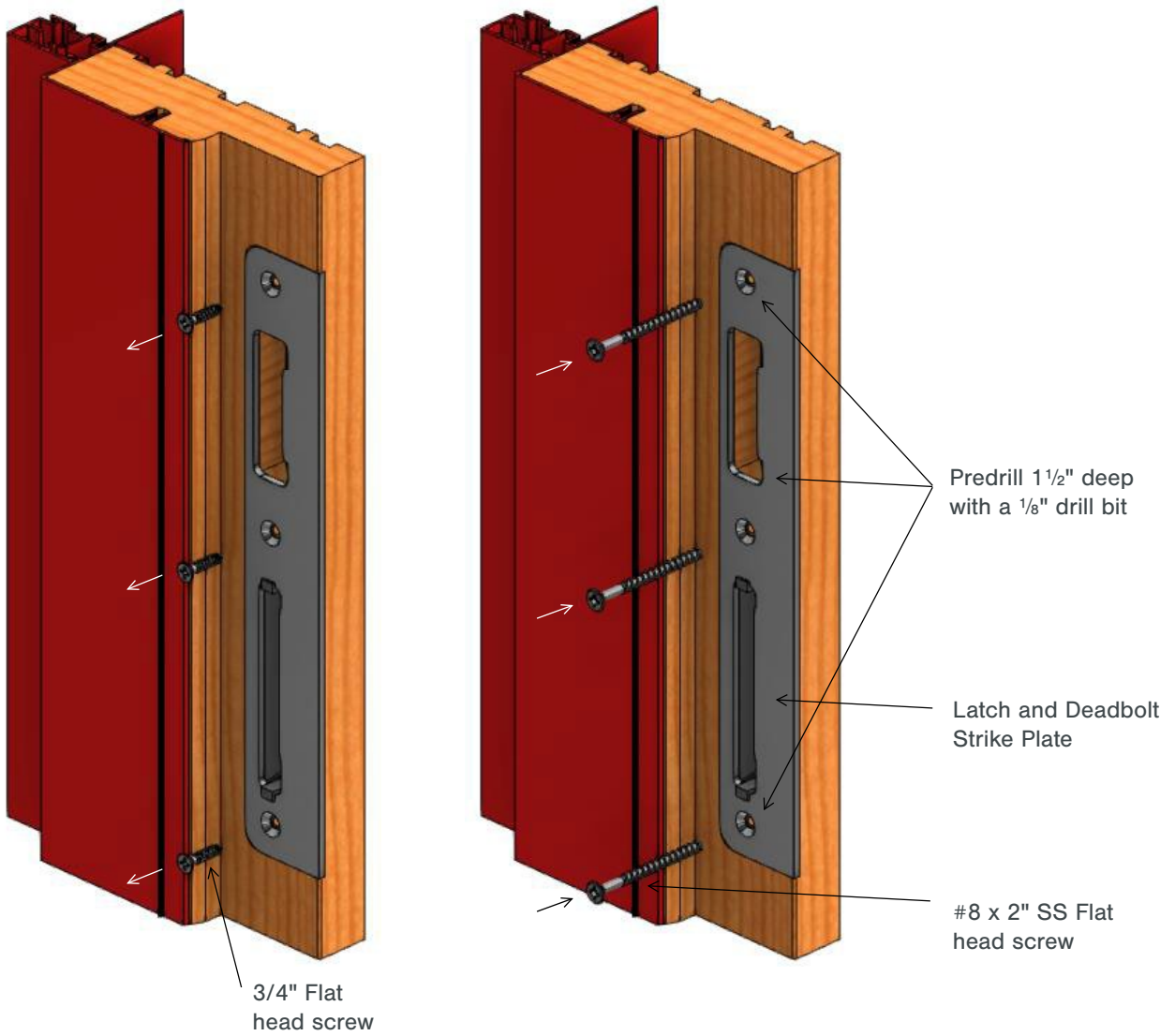

Information subject to change without notice.

Distributed by Loewen Inc. in the USA and C.P. Loewen Enterprises Ltd. in Canada and internationally. Trade Marks owned by C.P. Loewen Enterprises Ltd. Used under license.  
© C.P. Loewen Enterprises Ltd. All rights reserved

P1015A - 0424

The Loewen logo is presented in a white, elegant script font, centered within a solid red rectangular background.

[LOEWEN.COM](http://LOEWEN.COM)