



MULTI-SLIDE DOORS INSTALLATION GUIDE

and Site Preparation

Loewen

IMPORTANT NOTICES & INFORMATION

The building envelope must be correctly prepared with weather resistant barriers – that meet local and state codes. All frame and sill surfaces must be correctly prepared for air, water, and structural integrity by the builder or contractor before attempting installation. In order to meet warranty requirements, all systems are required to be installed by a certified installer.

- Read these instructions in their entirety prior to installing windows. Contact Loewen at 1.800.563.9367 for clarification.
- Loewen is not responsible for site measurements nor the structural and architectural requirements for the installation of the MultiSlide doors.
- Building design, construction methods, building materials and site conditions unique to your project may require methods different from these instructions.
- Choosing the appropriate method is the responsibility of you, your architect, or your construction professional.
- Confirm with sealant/foam/barrier manufacturers that all materials used are compatible with one another.
- Remove shipping blocks and related staples prior to installation.
- All drawings are shown not to scale.
- To ensure accuracy, make sure you have the latest approved shop drawings and assembly and installation guides.
- Any local, regional or national building code requirements supersede these instructions.
- Safety is top priority for Loewen. Use proper work procedures and protective equipment.

Notes on Building Envelopes

Improper design and/or non-conforming application of building envelope materials has been demonstrated to cause premature building envelope failure. Even with premium materials, shortcuts and errors in the final installation can impact budgets, time frames, building life span, and increase legal liabilities.

As one of the elements that bisect the interior/exterior plane, window and door integrations are a critical element of the building envelope as a whole. Poor installations can carry significant liability, due to building envelope failure.

Finishing Requirements

Metal Clad:

- Interior - within 14 days of installation.
- All door panels - Interior - immediately upon installation.

Non-clad:

- Exterior - immediately upon installation.
- Interior - within 14 days of installation.
- All door panels - Interior and Exterior - immediately upon installation.

Factory primed:

- Exterior - within 14 days of installation.
- Interior - within 14 days of installation.
- All door panels - Interior and Exterior - immediately upon installation.

See Loewen warranty and finishing guidelines at www.loewen.com

PREPARATION INSTRUCTIONS

Site Preparation Advisory

These instructions request that the building envelope include proper rough opening support with weather resistant barriers to meet or supersede all local building codes.

Tools Required

- Laser Level
- Hammer
- Pry Bars
- Ladders
- Utility Knife
- Screw Gun Applicator
- Foam Gun
- “J” Roller
- Tape Measure
- Caulk Gun

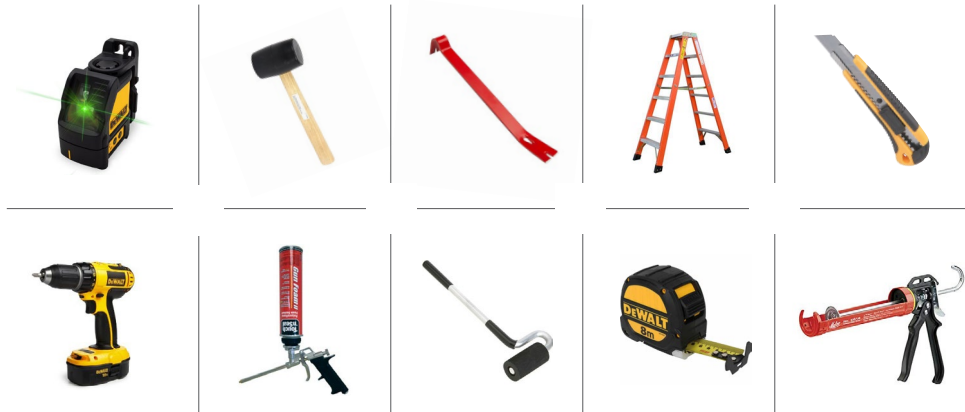

Suggested Materials Required

- High Impact Composite (not wood) shims/spacers
- 1 1/2” or 2” #8 Screws (stainless steel recommended)
- Expansion Foam - Closed Cell (low-expansion only)
- Window & Door Flashing Tape (6” recommended)
- Window & Door Sealant
- Interior Trim



Weather Barrier Material Selection

Though this guide only includes one type of barrier material, various options are available to meet individual site requirements:

- Vapor Permeable Building Wraps
- Fluid Applied Materials
- Self-Adhered Membranes
- Medium Density Spray-Polyurethane Foam
- Rigid Board Stock Insulation
- Factory-Bonded Membranes to Sheathing

ATTENTION:

Installation sealants must be chemically compatible with the rubberized asphalt membrane applied to the sill assembly. Synthetic copolymer sealants are not recommended. Incompatible sealants may cause irreparable harm to the sill system.

Product Adjustments

Adjustments to Loewen products are required as part of the installation process. It is up to the installer to ensure that all products operate properly and seal adequately.

Adjustments to hinges and other hardware to achieve uniform reveals and consistent weatherstrip contact should be made and verified during the installation.

Should technical support be required please contact us at 1-800-563-9367.

GENERAL INFORMATION ON INSTALL

Note:

The preparation of the rough opening for large openings such as those required by, but not limited to, LiftSlide, Bifold or Multi Slide doors have unique requirements.

Structural headers that allow for deflection no greater than 1/8" along the unsupported length once the header is fully loaded are required. Special care needs to be taken when installing any unit including transoms above such large opening units.

This manual is intended for construction professionals with proven competency installing doors for large openings. It is also recommended that certified installers are being used when installing this product.

This installation describes and recommends proper installation methods to ensure air, water and structural integrity will be maintained for maximum performance. During installation the Fit, Finish and Function will be critical to get it right the first time by making sure to perfectly level the sill and maintain a square opening.

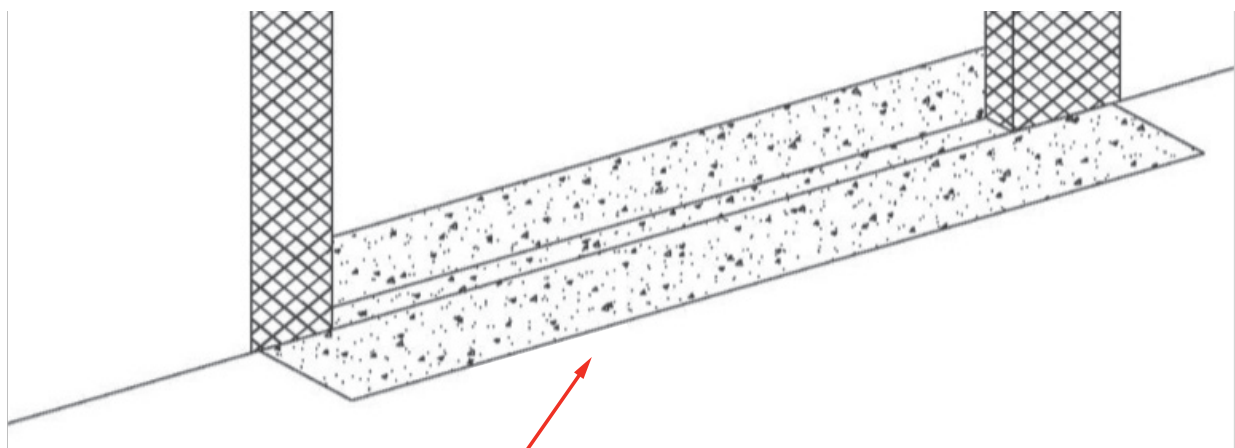
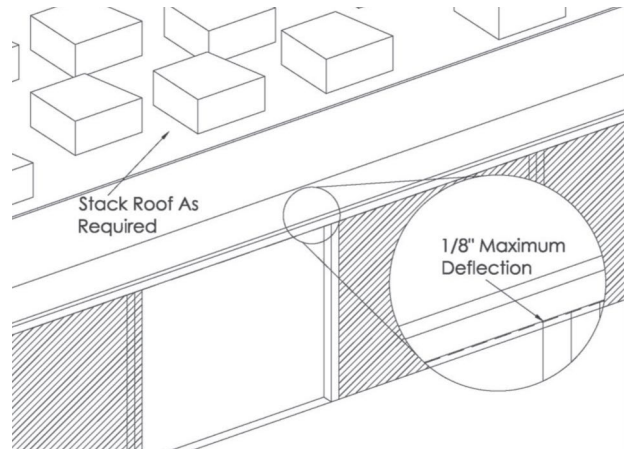

Sill Pans must be used in every installation of a Loewen MultiSlide system.

PRE-INSTALLATION CHECK LIST

You must work from the provided drawings to prepare the opening.

- The rough opening is the correct size, plumb and square. No sagging header. Take into account if the roof has been loaded or not. The maximum deflection over entire length of opening should not exceed 1/8" max. After the roof is loaded.
- Verify that the concrete or sub-floor where the system is to be installed is level. The frame system may be shimmed to compensate for an uneven floor but will adjust the relationship of the systems sill to the finished floor and may increase the overall height of the system in the opening. Any serious deflection in the concrete or sub-floor where the system is to be installed must be corrected prior to installation.
- It is important that your Framers knows the finished floor thickness to determine the header height.
- MultiSlide sills come in a variety of riser heights and should be noted as to the one specified for your application.
- The level of the finish floor needs to be determined ahead of time and noted somewhere near the opening.
- Exterior surface must have a negative slope from the sill assembly to allow water run-off from weep system (Recommend 2 degrees)
- Seal and Finish all the Panels and wood surfaces (specifically the edges) prior to installation, as it will be difficult to finish after the panels are installed. It also protects the wood from swelling and contracting, which can damage the wood itself and cause problems with operation.
- Once the doors are installed, it is difficult to access the overlapping stiles on the doors for any adjustment or finishing.
- Either wood framing or a continuous plane of plywood should be in place to anchor the head and/or side jamb.

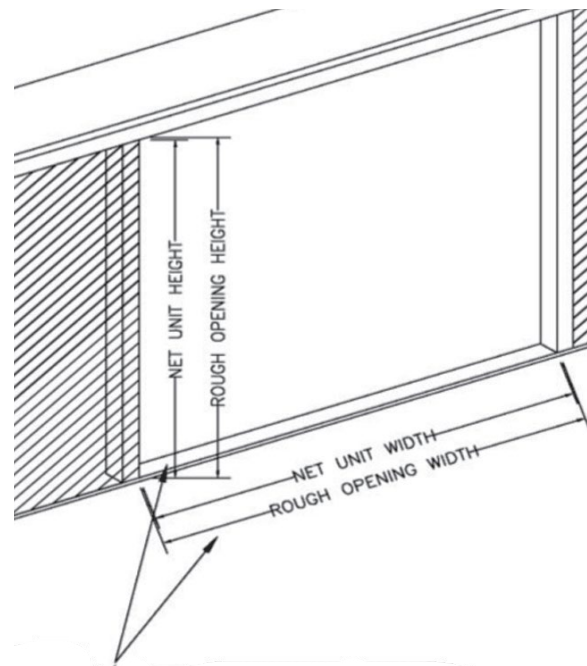

Verify unit and rough opening dimensions match drawing provided.

Pocketing Systems:

Insure that the finished pocket width and depth is correct. These dimensions are referenced in your drawings. The outside wall of the pocket needs to be framed in and sheathed according to the building codes in your area.

Wait to build the interior pocket walls until after the installation of the doors. This will allow easier access to the exterior pocket walls for installation of the head and bottom track; easier installation of the panels once the head and bottom track have been installed.

A certain amount of the interior pocket wall surfaces will be visible so it is best to paint the interior surfaces black. Do this before the doors are permanently installed.

INSTALLATION INSTRUCTIONS

Sill Pans and WRB

- Sill Pans can be rigid or flexible and are a highly recommended option to be used, sill pans are supplied by the contractor / builder.
- Pan flashing is used at the base of openings and designed to collect and drain water directly to the exterior or onto the weather resistive barrier.
- Sill Pans should be slightly sloped outward with a minimum 6" end dam, 1/2" interior upturn leg and 2" exterior down turn leg.
- Before fastening the rigid sill pan, apply three heavy 3/8" rounded bead of OSI Teq Seal onto the construction plate, one outboard, inboard and at the exterior down turned leg. Continue the sealant approx. 6" up both jambs at each end.
- Set the pan into the sealant and check for level. Secure the end dams with fasteners as required.
- Seal the end dams with sealant; tool the end dams to the framing
- **All installations must have a weather resistant barrier. WRB should be applied and fastened per manufacturers instructions.**
- If WRB wrap is applied then cut away with a complete box cut of the opening.
- NO WRB should be brought into the rough opening.
- Cut back and expose the sheathing at the side jambs by removing approximately 1 1/2" of WRB. This will create direct-contact seal to the sheathing for flashing
- Flash the opening jambs and head with OSI TeQ Flash™ before the door is installed.
- Ensure that the flashing and the sill pans are properly overlapped and remain water resistant.



Flexible Sill Pan Installation



Rigid Sill Pan Installation

IMPORTANT:
Installation sealants must be chemically compatible with the rubberized asphalt membrane applied to the sill assembly. Synthetic copolymer sealants are not recommended. Incompatible sealants may cause irreparable harm to the sill system.

INSTALLATION INSTRUCTIONS

Frame Prep and Assembly

1. Ensure you have the current version drawings before starting.
2. Verify the rough opening matches the RO dimensions on the drawing. Verify the finished floor thickness to determine the header height.
3. **Set up the laser level into the center of the room and find the high spot, reference the sill from there.**
4. Remove the screws from the lid on the plywood box; it will contain the bottom track, head track, jambs and accessories.
5. Lay frame head, sill and side jamb(s) on a flat surface. There are 3 sets of foam sealing pads to be applied.
6. Apply foam sealing pads to ends of side jambs as shown and caulking to top and bottom of jamb legs. Once gaskets are in place, raise the frame head, sill and side jamb(s) on a flat surface with the exterior side up. **(And/or post interlock(s) for pocketing systems only)**
7. Align the left side jamb to the outside top left edge of the head. Attach the left side jamb to the head using screws supplied in the “Jamb Assembly” screw package. Repeat to attach right side jamb or post interlock.
8. Align left side jamb to the outside bottom left edge of the sill. Attach the left side jamb to sill using screws supplied in the screw package. Repeat step to attach right side jamb or post interlock.

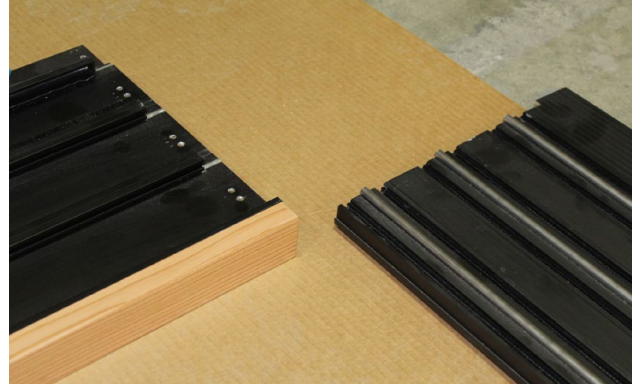

Lay frame head, sill and side jamb(s) on a flat surface

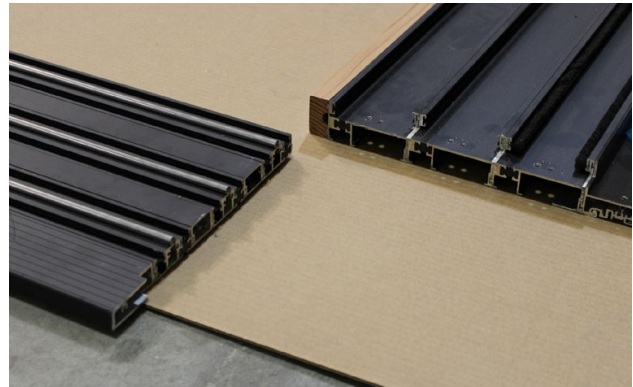

INSTALLATION INSTRUCTIONS

Apply Foam Sealing Pads & Caulking

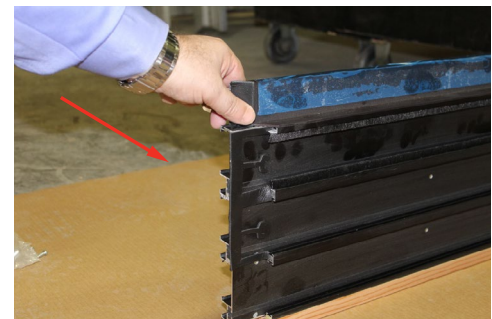
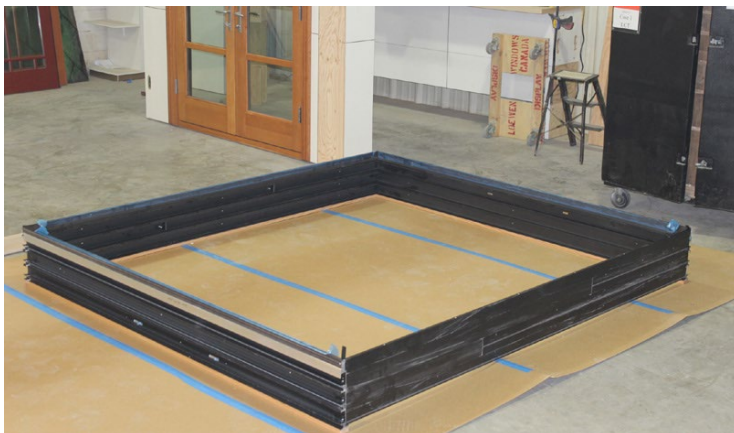
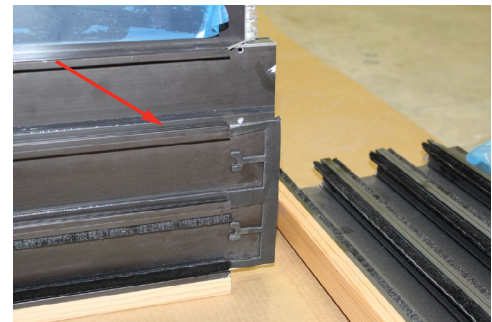
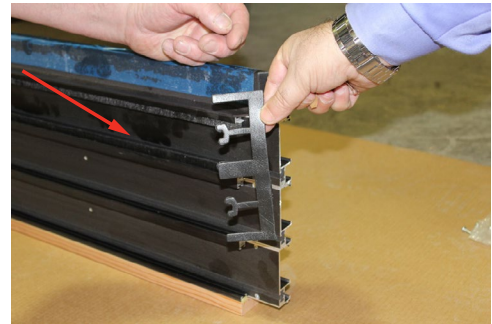
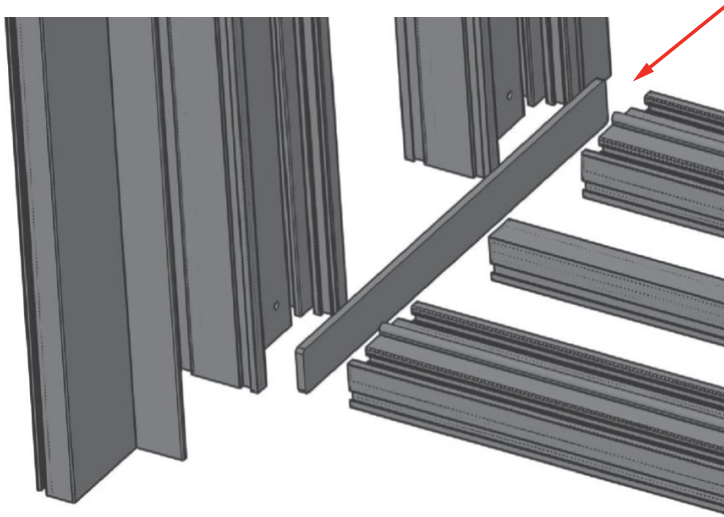

INSTALLATION INSTRUCTIONS

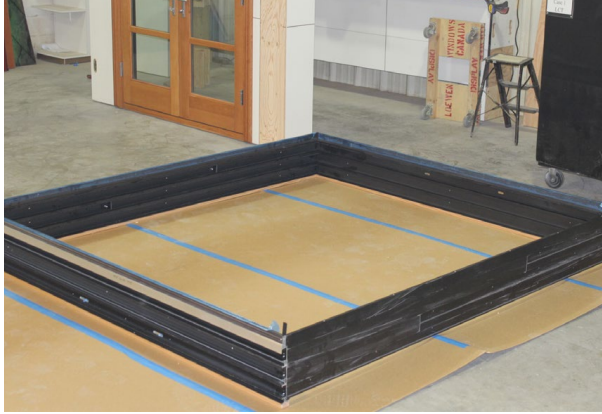

1. Align the left side jamb to the outside top left edge of the head. Attach the left side jamb to the head using screws supplied in the “Jamb Assembly” screw package. Repeat to attach right side jamb or post interlock.
2. Align left side jamb to the outside bottom left edge of the sill. Attach the left side jamb to sill using screws supplied in the “Jamb Assembly” screw package. Repeat step to attach right side jamb or post interlock.

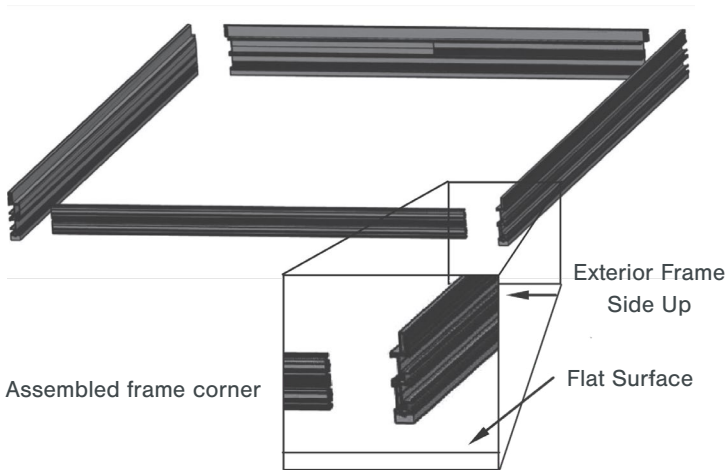

INSTALLATION INSTRUCTIONS

Frame Installation

1. Stand assembled frame up and set in prepared opening. **Note: Unit is supplied with nail flange for RO placement and to provide additional water and air resistance, when installed with correct flashing and WRB application techniques.**
2. Drill concrete for anchor screws located in the sill install screw package through the factory predrilled holes located in the sill. Attach using Tapcon masonry fasteners (located in sill install screw package) through the factory pre-drilled installation holes. **NOTE: Inject sealant into the holes prior to installing the screws and seal the over the fastener heads once installed. Every factory pre-drilled hole must be sealed and anchored. See page 17 for installation screw placement, ensure that only installation holes are used, do not drill or fasten through drainage holes in adjacent inboard channel.**
3. Prior to attaching the head, square the frame to within the allowable tolerances. Using a straight edge and/or level, verify that the top track/head is level and flat.
4. Use shims as needed to level and flatten the head. Attach the head through the pre-drilled holes (Fill all screw holes with silicone bead) using the screws located in the head install screw package.
5. Using a straight edge and/or level, verify that the side jambs are level and flat. Use shims as needed to level and flatten the jambs. Attached the side jambs through the factory pre-drilled holes (Fill all screw holes with silicone bead) using the screws located in the jamb install screw package.
6. Cross measure the frame to confirm there is no variance larger than 3/16" per measurement and that the frame is square to within 1/8" horizontally and vertically.



Head flashing with appropriate fasteners. Seal over fasteners with Sealant.

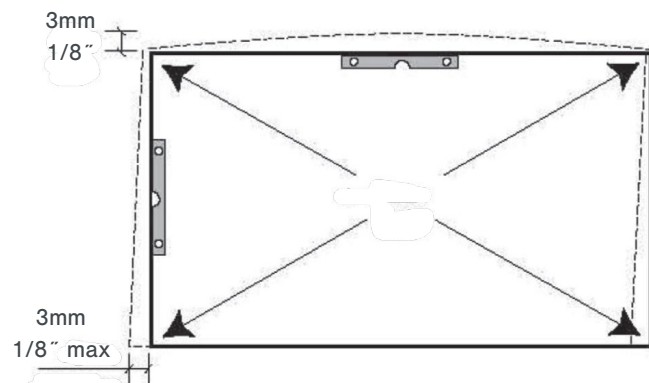
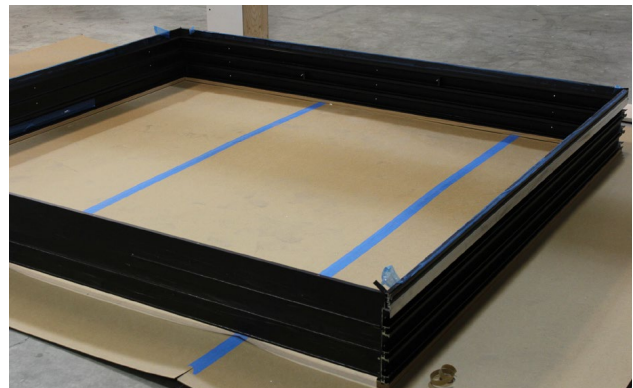

INSTALLATION INSTRUCTIONS

Apply Foam Sealing Pads & Caulking

7. Fill all screw holes with silicone bead and apply all remaining screws into predrilled holes.
8. Appropriate rigid head flashing must be installed across the top of the unit. Secure the
9. Interior seal: It is critical to fill the exterior 2" of the rough opening with low expansion foam. From the interior, insert the nozzle of the applicator into the rough opening, hold the tip of the nozzle 1" (25mm) back from the exterior nail flange and apply a minimum 2" (50mm) bead of foam into the rough opening on top and both sides.
10. Check and re-check to make sure that the foam has made complete contact between the door and framing to both surfaces. Check Sill again to ensure no deflection.



Final door assembly (panel installed for reference only)

INSTALLATION INSTRUCTIONS

Panel Installation

1. Beginning with panel marked #1, holding the panel at an angle toward the head track, insert the top of the panel into the inner most head track and swing the bottom of the panel inward until it is parallel with the top and sits with the wheels on the corresponding sill.
2. Push panel #1 to the fixed panel jamb (for stacking systems) or into the pocket (for pocketing systems)
3. Repeat step for all remaining panels in sequential order.

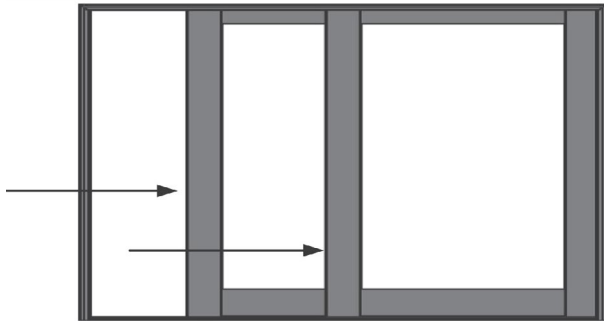
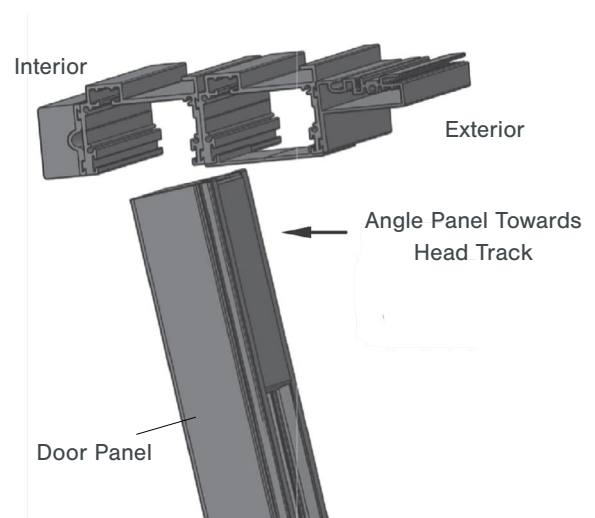

INSTALLATION INSTRUCTIONS

Adjustments

1. Once all panels are installed, close the system and make sure all panel stiles line up properly by adjusting wheels for proper alignment.
2. Access to wheel adjustment through holes in bottom rail.
3. Wheel adjustments should be used for final tuning only. Once adjusted, tighten all wheels to the same approximate pressure to allow for even panel weight distribution.



Flush Handle

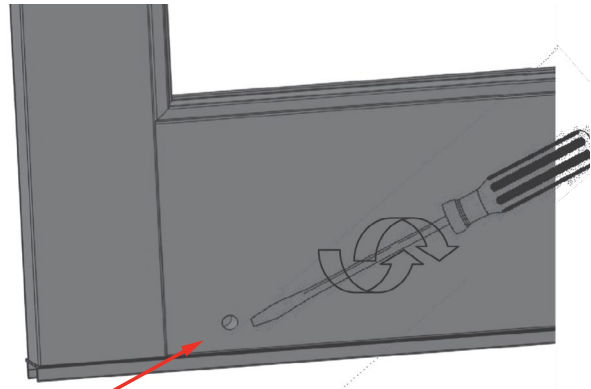

Wheel Adjustment Access Holes



Glide Roller Assembly

INSTALLATION INSTRUCTIONS

Installing Head Tracks Covers and Slide Jamb Covers

Head track covers finish the look of the MultiSlide and provide a protective barrier to the exterior of the sliding tracks.

Header Track Panel stops need to be placed in each track where the head track covers will end. Location is easy to identify once all the door panels are closed. Use the pre-drilled holes to locate the correct positioning. Run sealant into the screw hole and attach stop. Trim the jamb and head covers to precise fit on site once the panels are installed

The Track covers can now be installed by placing one edge in the header groove and tapping into place with a rubber mallet on opposite side.

Once the Headers are complete the side jamb covers can be installed. All side tracks will have a cover – except the final interior track (with strike plate)

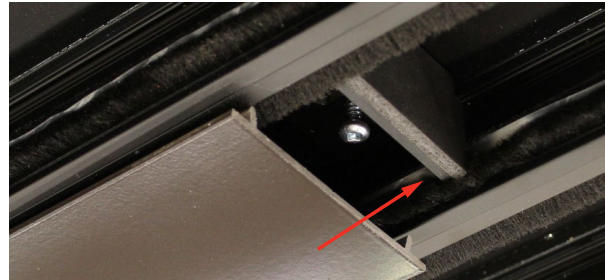

Flush Handle

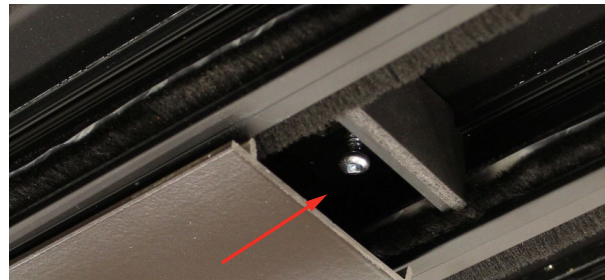

Head track cover will be installed after stops, shown for visual location only

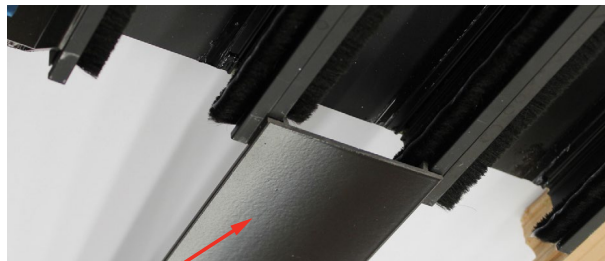

Track Cover



Interior track with spike plate



INSTALLATION INSTRUCTIONS

Follower/Pocket Closure Installation (for pocketing systems only)

On Pocketing systems an aluminum follower extrusion is attached to the back of the final panel. This holds the Pocket Skirt Board to seal and finish the interior pocket opening when the door is completely closed. The width of board is dependent on the number of pocketing panels.

From interior side of system, attach the aluminum follower to the back edge of the last (exterior) panel with supplied Bolts Attach the wood pocket trim panel to the aluminum follower using the screws supplied.

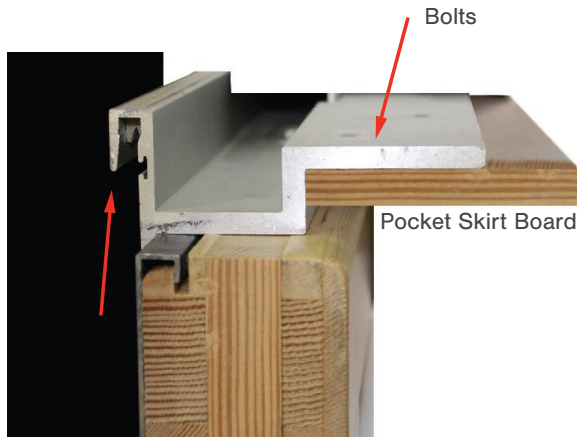

Exterior Stop

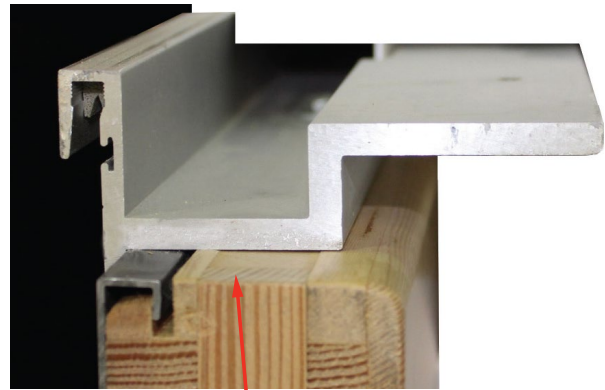

Wheel Adjustment Access Holes

The notched bottom end of the aluminum follower will fit over the top of the sill nosing extensions when attached.

Collector Installation

On multiple panels systems, a collector strip is attached to additional panels. (Excluding first interior and final exterior panel) This is mounted to top of door and allows all panels to open and stack together. Attach with screws supplied after door finishing and sealant is completed.



INSTALLATION INSTRUCTIONS

Sill Riser Options

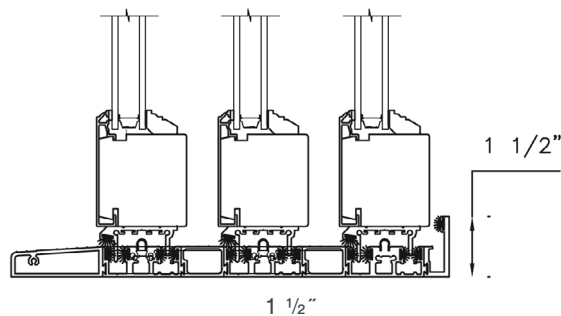
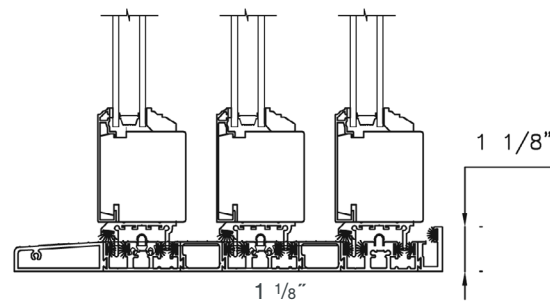
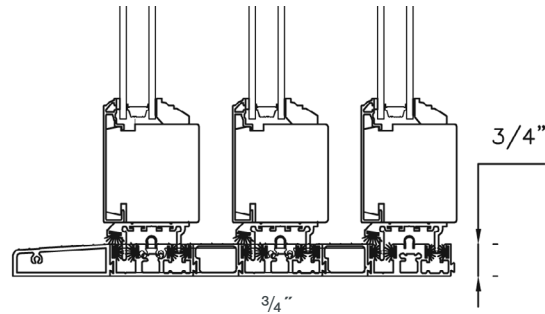

Notes:

- Drawings shown are typical details.
- Additional sizes and configurations available.
- Screen options may be available depending on size and configuration.
- Raised threshold available with a maximum of 6 panels per sill (12 in a bi-parting configuration; 2 per track).
- Consult your Authorized Dealer for details.
- All dimensions to have +/- 1/16" (2 mm) tolerance.
- O = Fixed
- X = Operating
- P = Pocketing
- The preparation of the rough opening for large openings such as those required by, but not limited to, LiftSlide, Bifold and MultiSlide doors have unique requirements. Structural headers that allow for deflection no greater than 1/8" along the unsupported length once the header is fully loaded are required. Special care needs to be taken when installing any unit including transoms above such large opening units.
- Loewen is not responsible for site measurements or the determination of structural and architectural requirements for the installation of large opening products such as but not limited to, Liftslide, Bifold and MultiSlide doors. Site specifications are the responsibility of building professionals or engineers to determine.

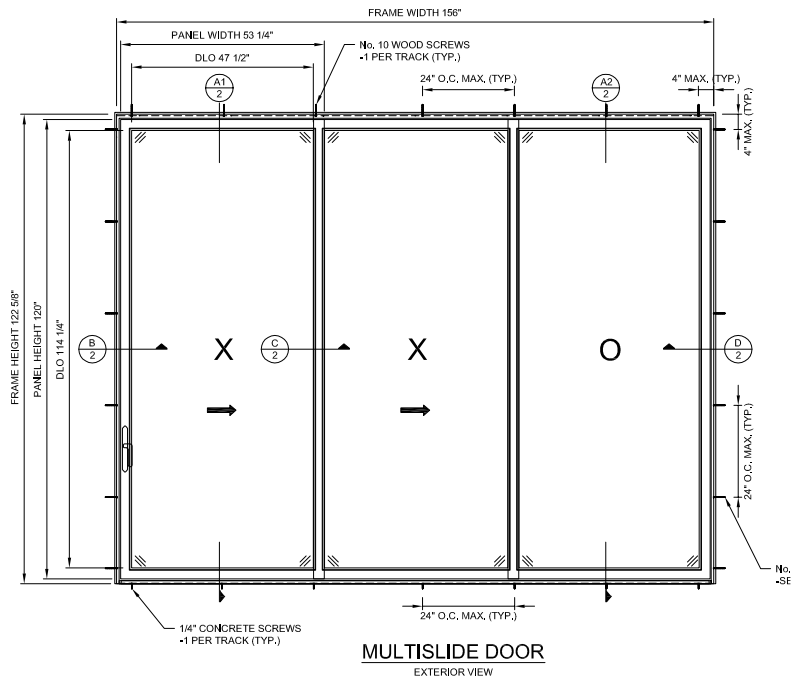
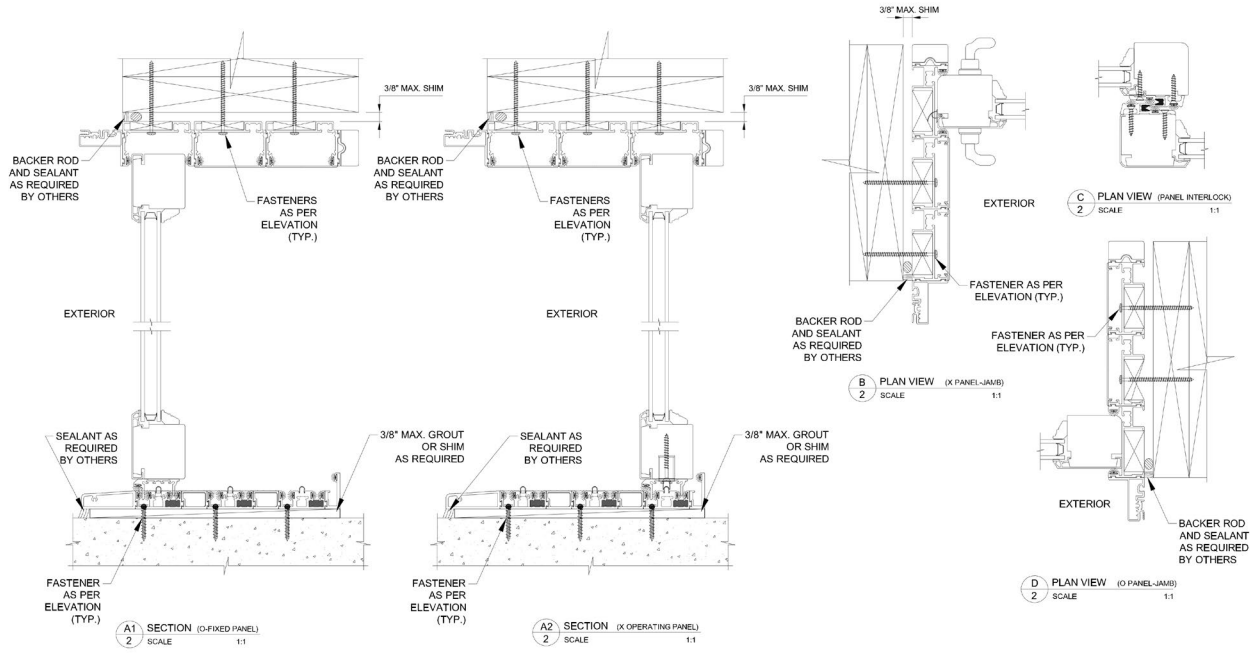

MULTISLIDE DOOR
EXTERIOR VIEW

Notes:

- Drawings shown are typical details.
- Additional sizes and configurations available.
- Screen options may be available depending on size and configuration.
- Raised threshold available with a maximum of 6 panels per sill (12 in a bi-parting configuration; 2 per track).
- Consult your Authorized Dealer for details.
- All dimensions to have +/- 1/16" (2 mm) tolerance.
- O = Fixed
- X = Operating
- P = Pocketing
- The preparation of the rough opening for large openings such as those required by, but not limited to, LiftSlide, Bifold and MultiSlide doors have unique requirements. Structural headers that allow for deflection no greater than 1/8" along the unsupported length once the header is fully loaded are required. Special care needs to be taken when installing any unit including transoms above such large opening units.
- Loewen is not responsible for site measurements or the determination of structural and architectural requirements for the installation of large opening products such as but not limited to, Liftslide, Bifold and MultiSlide doors. Site specifications are the responsibility of building professionals or engineers to determine.

Information subject to change without notice.

Distributed by Loewen Inc. in the USA and C.P. Loewen Enterprises Ltd. in Canada and internationally. Trade Marks owned by C.P. Loewen Enterprises Ltd. Used under license.
© C.P. Loewen Enterprises Ltd. All rights reserved.

0424

The Loewen logo is a red square containing the word "Loewen" in a white, elegant, cursive script font.